

TE'S RAYCHEM SCREENED COUPLING CONNECTORS RSTI-CC-X9

Large Cross Sections, 1250A up to 42 kV

Product Features:

- The screened coupling connector is designed to mate with the rear end of the RSTI base screened connector system designed for 42 kV
- The insulation of the coupling connector is made of a highly modified silicone rubber characterised by high tracking resistance, elongation at break and non-flammability
- A thin-walled screen is permanently bonded onto the insulation and protects the connection system against accidental contact
- The screened coupling connector need not be removed for oversheath testing
- The combination of screened connector and coupling connector exceeds CENELEC HD 629.1 S1 requirements, which include BS, VDE and other international specifications
- Design of combination fits 630A and 1250A bushings (Interface "C1" and "C2") as specified by EN 50180 and EN 50181
- The compact design supports the use of double «T» connections inside standard terminal boxes
- The wide application range covers cable cross-sections from 400 mm² to 1000 mm²
- Conductor connection with mechanical lugs
- Easily accessible rear plug with capacitive test point
- Few accessories required for system test and earth connection
- Complete kit including lugs for easier installation and storage

Design and construction:

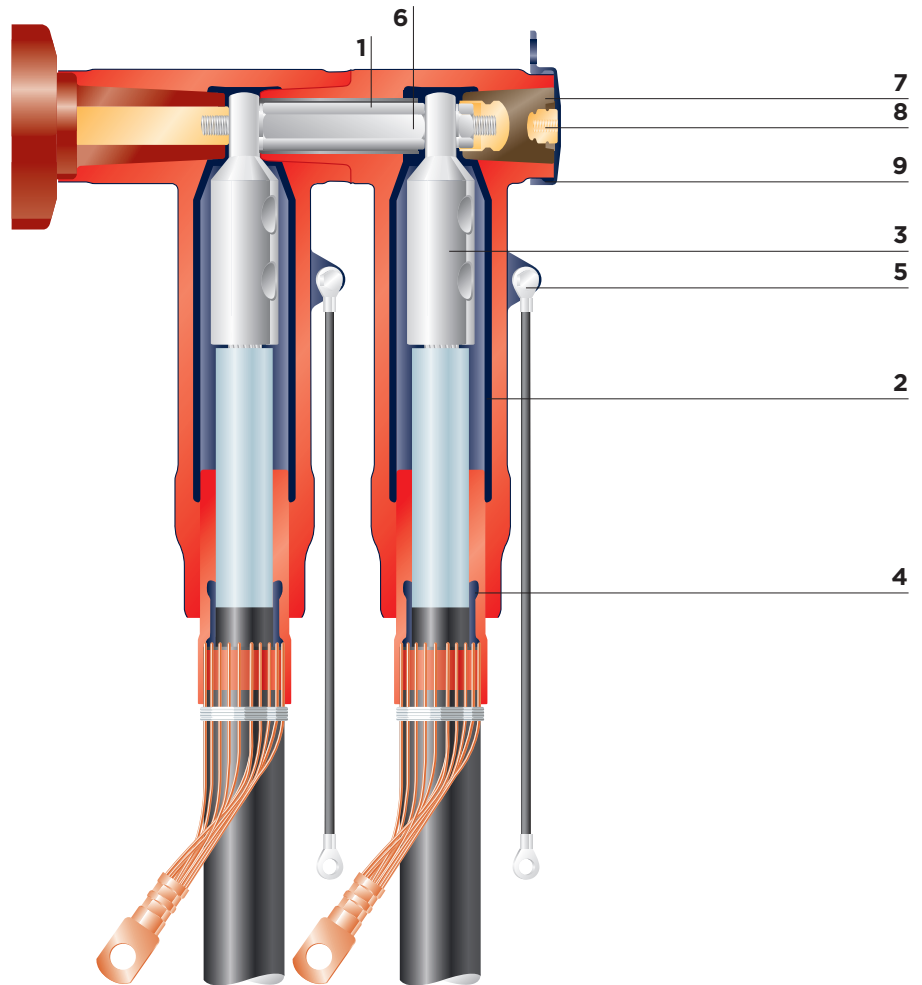

1. Screened body

A thin walled conductive outer screen is permanently bonded to the silicone rubber insulating material of the body.

2. Inner screen

A conductive inner layer, as a Faraday cage around the mechanical lug, prevents corona at rated voltage.

3. Mechanical lug

Specially designed mechanical lugs for connecting either aluminium or copper conductor cables.

4. Stress cone adapter

Relieves electrical stress at the point where the cable screen is cut. The insulated section, extending beyond the wire shielding, provides a convenient point for over sheath testing.

5. Earthing eye and ground lead

Provides a connection point for earthing the screen.

6. Threaded pin assembly

A threaded pin assembly together with a spring washer and hex nut ensure high-performance electrical and mechanical contact with the bushing.

7. Rear plug with test point

Removable rear plug with capacitive test point.

8. Test point

The test point is used to determine whether the circuit is energised; alternatively it can be used for phasing.

9. Conductive end cap

Electrical screen and protection of the rear end of the separable connector.

Applications

DOUBLE CONNECTION

Material required for 3 phases:
1 x RSTI-x95x (Basic kit)
1 x RSTI-CC-x95x (Coupling connector kit)

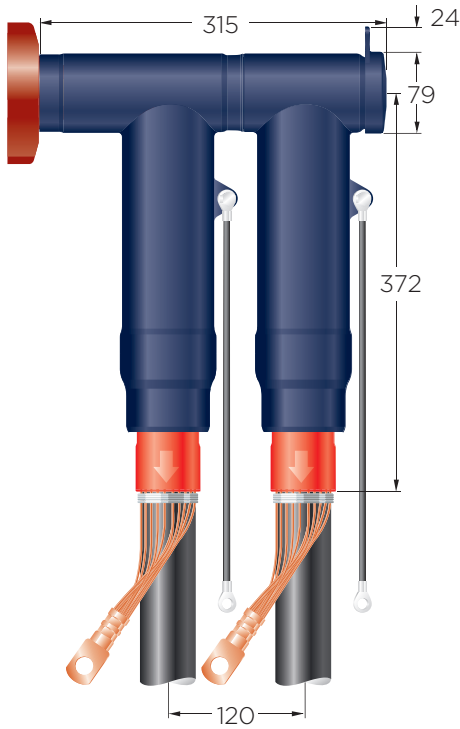

SINGLE CORE BRANCH OFF

Items required for 3 phases:
1 x RSTI-x95x (Basic kit)
1 x RSTI-68TP (Terminating plug kit)
2 x RSTI-CC-x95x (Coupling connector kit)

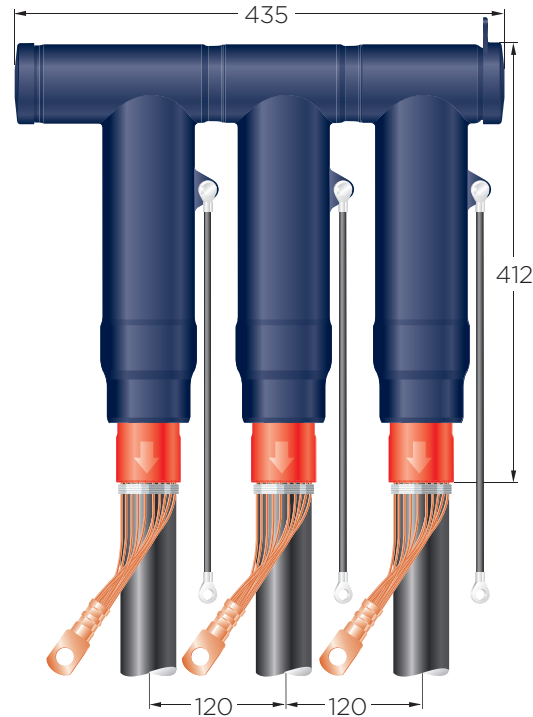

Accessories

TEST ROD

Ref. no.: RSTI-68TR; Length: 310 mm
RSTI-68TRL; Length: 460 mm
RSTI-68TRA; Kit includes
2 short and 1 long test rod



TERMINATING PLUG

Ref. no.: RSTI-68TP

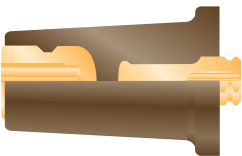

INSULATING CAP

Ref. no.: RSTI-68RC
One piece per set



Cross Section (mm ²)	OF CONNECTOR BODY MAX Ø		
	12 kV	24 kV	42 kV
630	90	94	99
800	94	98	103

DISCONNECTABLE INLINE JOINT

Items required for 3 phases:
1 x RSTI-x95x (Basic kit)
1 x RSTI-68TP (Terminating plug kit)
1 x RSTI-CC-x95x (Coupling connector kit)

Note: All applications as shown in the brochure need to have a mechanical support, based on the requirements for dynamic short circuit.

EARTHING ADAPTER

Ref. no.: RSTI-68EA20;
Ball diameter: 20 mm
RSTI-68EA25;
Ball diameter: 25 mm

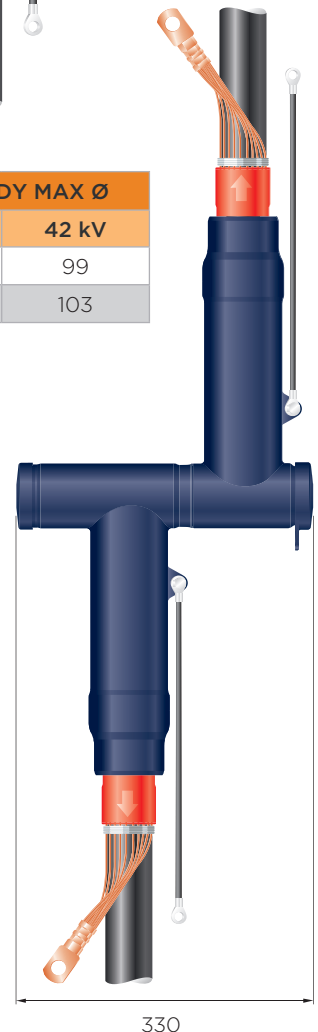
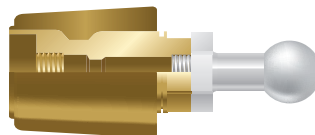

TECHNICAL DATA FOR RSTI-CC-68

Cable insulation diameter range	28.9 mm - 59.0 mm
Connector cross-section range	400 mm ² - 1000 mm ²
Maximum system voltage	42 kV
Continuous current rating	1250A*
Basic impulse level	200 kV
Partial discharge at 2 U ₀	< 2 pC
AC voltage withstand, 5 min.	93.5 kV
DC voltage withstand, 15 min.	125 kV
Thermal short circuit, 1 s	74.5 kA
Thermal short circuit, 3 s	43 kA
Dynamic short circuit	125 kA

* 1250 A is relevant for upgraded bushing C2 and cables with copper conductors

The adapters meet the international CENELEC HD 629.1 S2 specification.

SELECTION TABLE

Cross Section (mm ²)	Diameter Core Insulation (mm)		Reference Number Conductor Material
	min	max	AL or CU
SCREENED SEPARABLE CONNECTION SYSTEM 12 kV WITH MECHANICAL LUGS			
400	28.9	36.4	RSTI-CC-3951
500	28.9	36.4	RSTI-CC-3952
630	34.0	45.4	RSTI-CC-3953
800	34.0	45.4	RSTI-CC-3954
1000	39.1	59.0	RSTI-CC-3955
SCREENED SEPARABLE CONNECTION SYSTEM 24 kV WITH MECHANICAL LUGS			
400	34.0	45.4	RSTI-CC-5951
500 - 630	34.0	45.4	RSTI-CC-5952
630	39.1	59.0	RSTI-CC-5953
800	39.1	59.0	RSTI-CC-5954
1000	39.1	59.0	RSTI-CC-5955
SCREENED SEPARABLE CONNECTION SYSTEM 36 kV WITH MECHANICAL LUGS			
400	34.0	45.4	RSTI-CC-6951
500 - 630	39.1	59.0	RSTI-CC-6952
800	39.1	59.0	RSTI-CC-6953

te.com/energy

©2021 TE Connectivity Ltd. All Rights Reserved. EPP-1757-02-21

TE Connectivity, TE connectivity (logo), EVERY CONNECTION COUNTS, AMP, AMPACT, Bowthorpe EMP, Crompton Instruments, Raychem, SIMEL, UTILUX are trademarks. Other logos, product and Company names mentioned herein may be trademarks of their respective owners. While TE has made every reasonable effort to ensure the accuracy of the information in this brochure, TE does not guarantee that it is error-free, nor does TE make any other representation, warranty or guarantee that the information is accurate, correct, reliable or current. TE reserves the right to make any adjustments to the information contained herein at any time without notice. TE expressly disclaims all implied warranties regarding the information contained herein, including, but not limited to, any implied warranties of merchantability or fitness for a particular purpose. The dimensions in this brochure are for reference purposes only and are subject to change without notice. Specifications are subject to change without notice. Consult TE for the latest dimensions and design specifications.

**FOR MORE INFORMATION:
TE Technical Support Centers**

USA/Canada:	+1 800-327-6996
Brazil:	+55 11-2103-6023
Mexico:	+52 55-1106-0800
South America:	+57 1-319-8962
Benelux:	+32 16-508-695
France:	+33 (0) 38-058-3210
Germany/Switzerland:	+49 (0) 89-608-9903
Italy:	+39 335-834-3453
Middle East/Africa:	+971 4-211-7020
Russia:	+7 495-790-790-2-200
Spain/Portugal:	+34 912-681-885
UK:	+44 08708-707-500
China:	+86 400-820-6015



TE's Raychem Cable Accessories

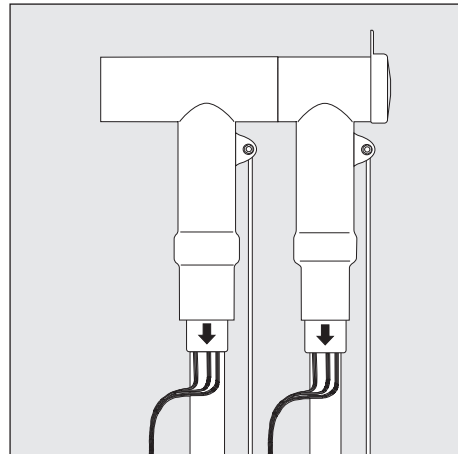

Installation Instruction EPP-1770-8/18

**Raychem
Screened Separable
Coupling Connector
up to 1250 A for
Fit onto Base Connector Type
RSTI-x95x used with
bushings Type "C"
according to EN 50181
and screened Single Core
Polymeric Insulated Cable
up to 42 kV**

Type: RSTI-CC-x95x

Safety Warning:

It is essential to observe the applicable safety regulations for working with high voltage equipment.

For precise safety information please contact the responsible authority.

To view the TE Energy website:



Tyco Electronics Raychem GmbH
a TE Connectivity Ltd. Company
Finsinger Feld 1
85521 Ottobrunn/Munich, Germany
Tel: +49-89-6089-0
Fax: +49-89-6096-345
TE.com/energy

Before Starting

Check to ensure that the kit you are going to use fits the cable.
 Refer to the kit label and the title of the installation instruction.
 Components or working steps may have been improved since you last installed this product.
 Carefully read and follow the steps in the installation instruction.

Kit Content

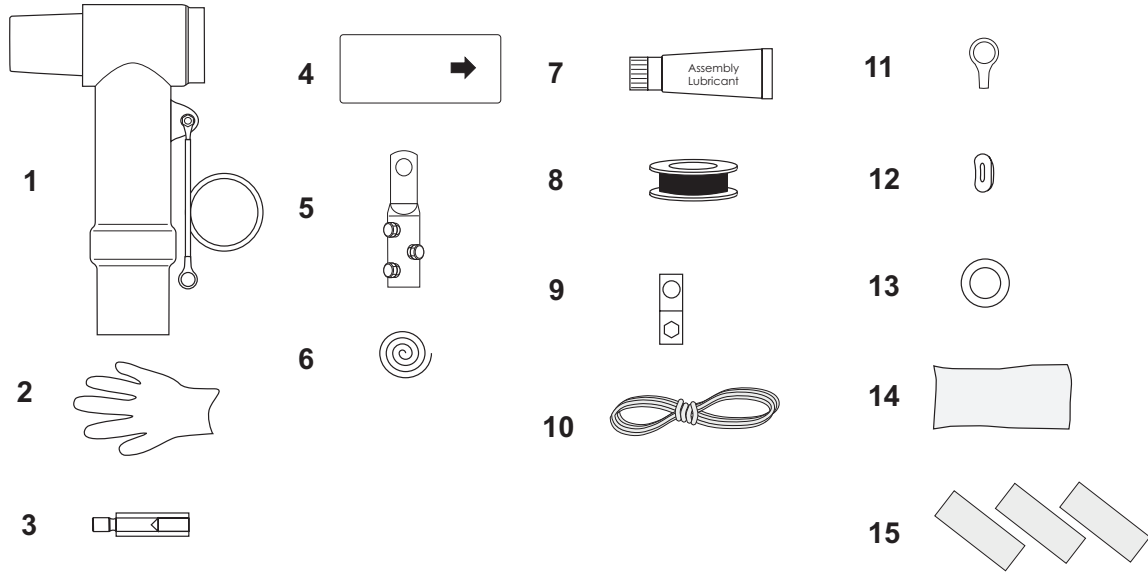

1	3 x Connector body	4	3 x Stress cone	7	2 x Assembly lubricant	11	3 x Screen cable lug
2	3 x Gloves	5	3 x Main cable lug	8	1 x PVC tape	12	3 x Spring washer (spare)
3	3 x Coupling bolt	6	1 x Binding wire	9	3 x Cable lug (16 - 70)	13	3 x Cu washer, tinned
				10	1 x String	14	3 x Protective bag
						15	3 x Sealing tape (grey)

Table 1

Cross Section	Voltage Class (U _m)/kV	Ø Core Insulation		Reference No. Al or Cu
		min	max	
400	12	28.9	36.4	RSTI-CC-3951
500		28.9	36.4	RSTI-CC-3952
630		34.0	45.4	RSTI-CC-3953
800		34.0	45.4	RSTI-CC-3954
400	24	34.0	45.4	RSTI-CC-5951
500 - 630		34.0	45.4	RSTI-CC-5952
630		39.1	59.0	RSTI-CC-5953
800		39.1	59.0	RSTI-CC-5954
400	36 & 42	34.0	45.4	RSTI-CC-6951
500 - 630		39.1	59.0	RSTI-CC-6952
800		39.1	59.0	RSTI-CC-6953

The Information contained in these installation instructions is for use only by installers trained to make electrical power installations and is intended to describe the correct method of installation for this product. However, TE Connectivity has no control over the field conditions which influence product installation.

It is the user's responsibility to determine the suitability of the installation method in the user's field conditions.

TE Connectivity's only obligations are those in TE Connectivity's standard Conditions of Sale for this product and in no case will TE Connectivity be liable for any other incidental, indirect or consequential damages arising from the use or misuse of the products.

Raychem, TE, TE Connectivity and TE connectivity (logo) are trademarks.

© 2018 TE Connectivity. All Rights Reserved.

Cable Preparation

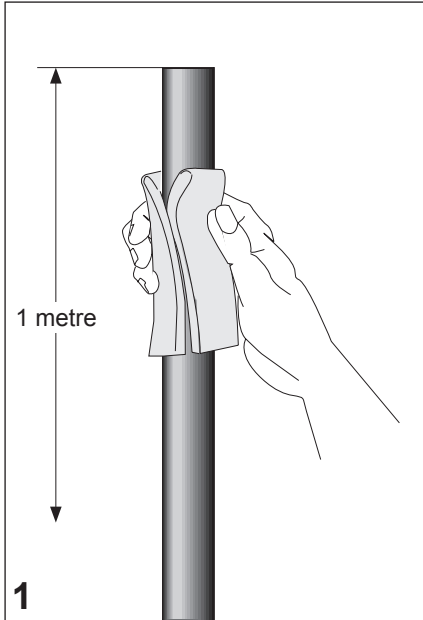

Preheat the cable and use appropriate devices to straighten the cable.

Clean and degrease the end of the overshath for a length of 1 metre with solvent wipe.

Cut the core according to the dimension given in the drawing. Remove the core screen with appropriate screen cutting tool according to the drawing. The surface of the insulation should be free from all traces of conductive material. Compare the diameter over insulation with application range as shown in **Table 1** as well as with marking of supplied stress cone.

Application Check!

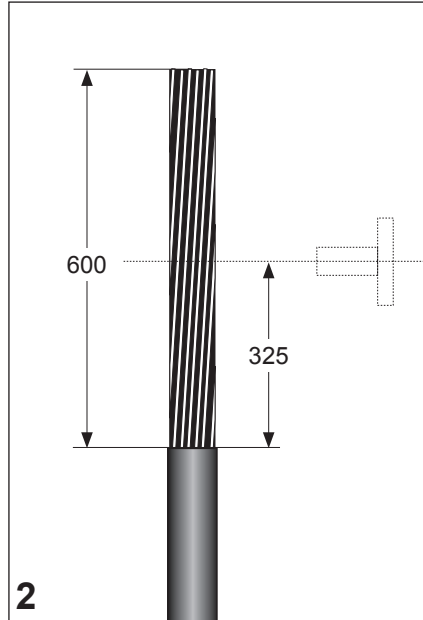
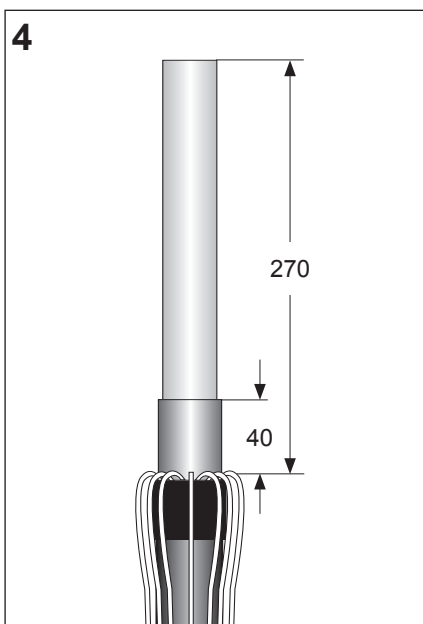

Cable with wire shield

Position the cable with sufficient overlap to the bushing centre. Mark the overshath 325 mm below the bushing centre. Cut the cable 600 mm above the mark and remove the overshath over this distance. Cut off Cu-spiral screening tape flush with end of outer sheath.

Edges projecting beyond the outer sheath **must be avoided**, so that the stress cone can not be damaged during push on procedure.

Cut back the insulation according to dimension **K** given in drawing details.

Dimension **K** is identical to depth of bore. Barrel butts against insulation!

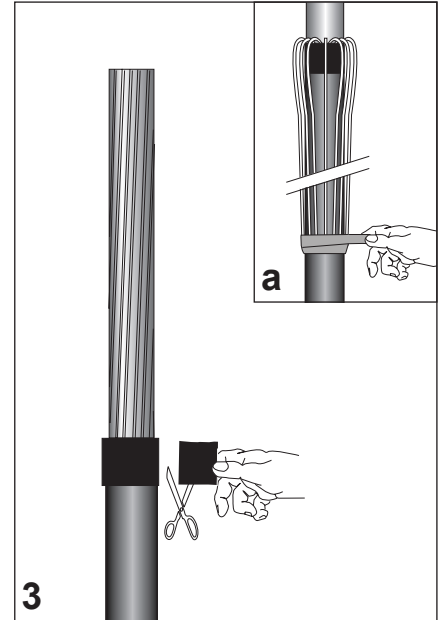
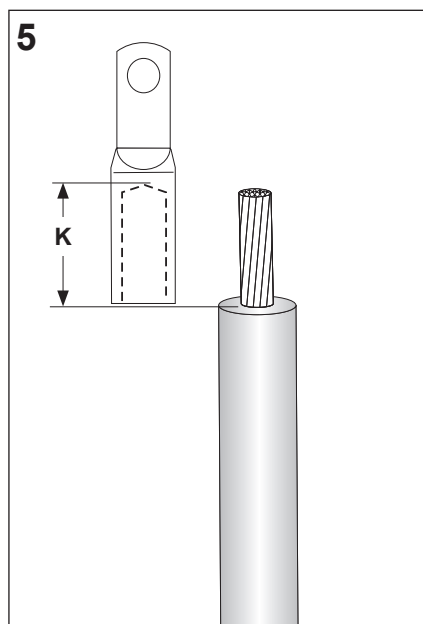

Wrap one turn of sealant tape (grey) with no overlap and slight tension around the end of the overshath.

Cut the tape and push ends together.

Bend the shielding wires back onto the overshath.

Avoid crossing the individual wires. Temporarily secure the wires with a tape or wire binder (see detail).

Recommendation for large cross sections

Convenient push on process of the stress cone requires chamfering of the insulation for cross section 240 mm² and above. See drawing!

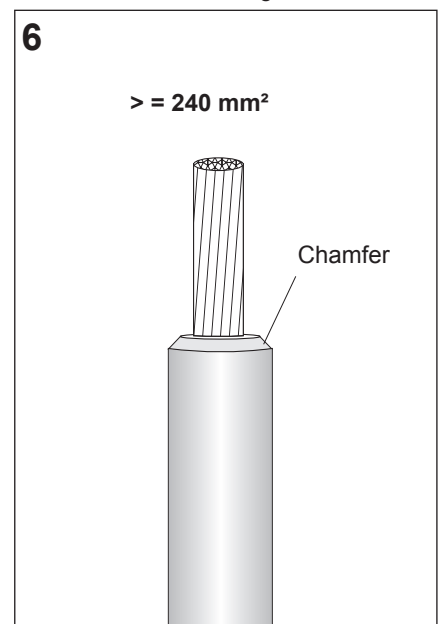

Core Preparation

Table 2 - Application Range of Mechanical Lugs

Part number	Cross section (mm ²)	Ø over round stranded Al or Cu conductors (mm)	Ø over round solid Al conductors (mm)
BLMC-400-16-1250A	400	19.7 - 24.6	19.8 - 22.2
BLMC-500/630-16-1250A	500 - 630	25.3 - 32.5	24.0 - 28.3
BLMC-800-16-1250A	800	32.5 - 35.3	30.9 - 32.1

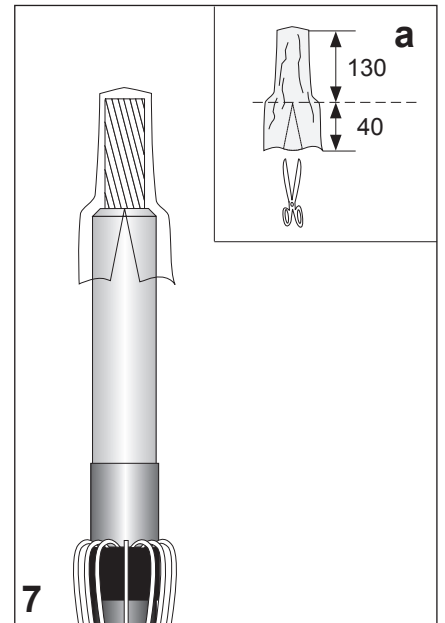

Cut the small protective bag (assembly aid) at the bottom end at a length of 40 mm on one side (see detail a).

Slide the protective bag over the exposed conductor as shown.

Tie the assembly aid down with a PVC tape as shown in the drawing.

Gently lubricate the outer surface of the protective bag and the core insulation with a thin layer of assembly lubricant. Apply the lubricant layer with the sponge top as shown.

Apply onto the inner surface of the stress cone at the bottom end a 5 cm long sausage of assembly lubricant and spread it evenly over the inner surface. Use assembly lubricant without sponge top. Push the stress cone in one sequence with a twisting movement over the assembly aid completely onto the insulation until the inner collar of the stress cone stops at the oversheath cut back of the cable.

Note: The arrow on the stress cone should point onto the cable sheath. Remove the assembly aid from the conductor.

Remove the assembly aid and install the cable lug using a lug fixture. Tighten the bolt set alternately in several equal steps until the heads shear off.

Remove any sharp edges.

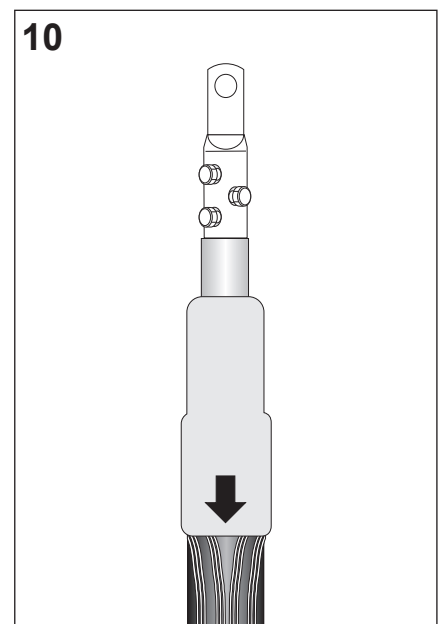
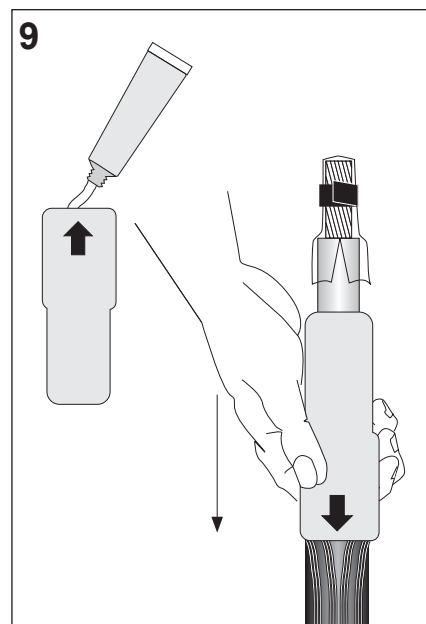
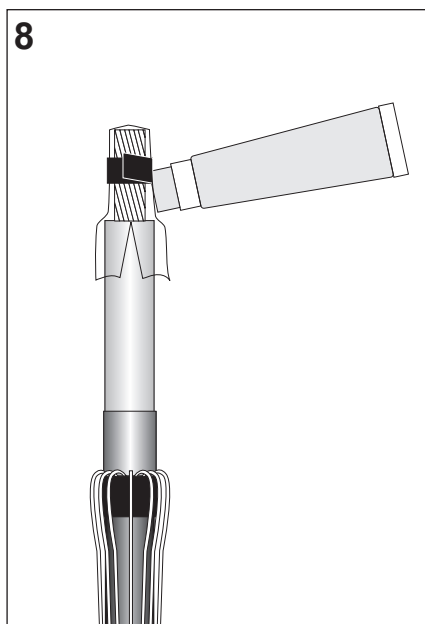

Preparation of Installed Screened Separable Connector

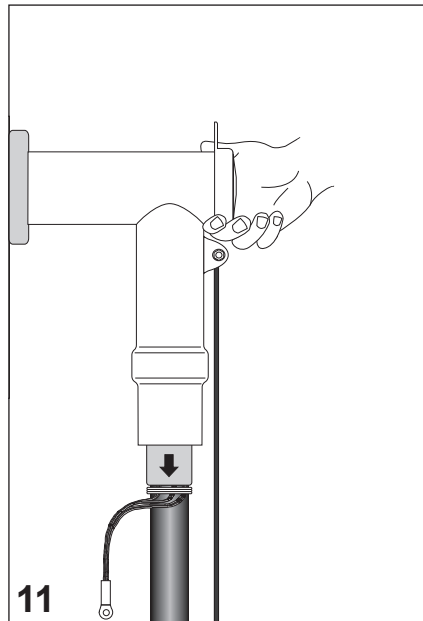

11 Remove from the installed connector the conductive endcap and save it in a clean container.

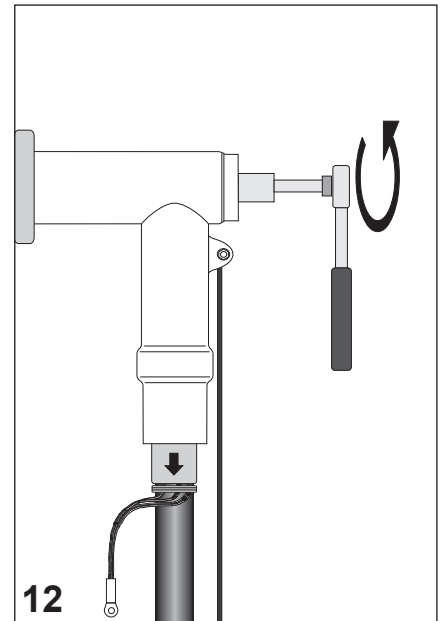

12 Remove from the installed connector the back plug and save it in a clean container.

Installation of Coupling Connector

Remove from the installed connector **hexagon nut, washer, threaded pin** and save it in a clean container.

Ensure that the rear end of the already installed connector is lubricated with a thin layer of assembly lubricant.

Insert coupling stud with tinned Cu-washer (see detail) into the rear end of the connector and tighten it up with a torque wrench (27 mm).

Maximum torque: **35 Nm**.

Insert the **threaded stud M16** into the rear end of the coupling stud and tighten it up with an Allen key (8 mm). Maximum torque: **30 Nm**.

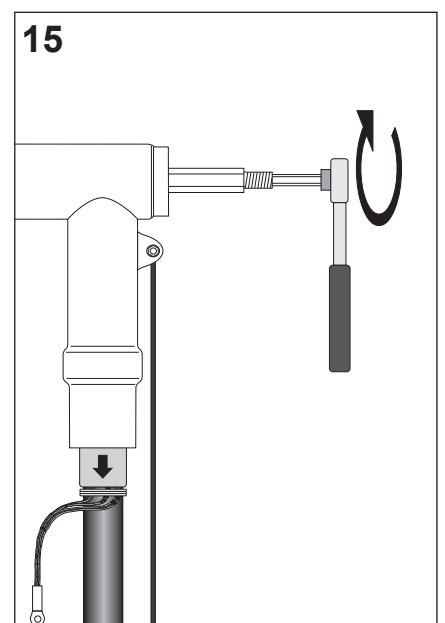
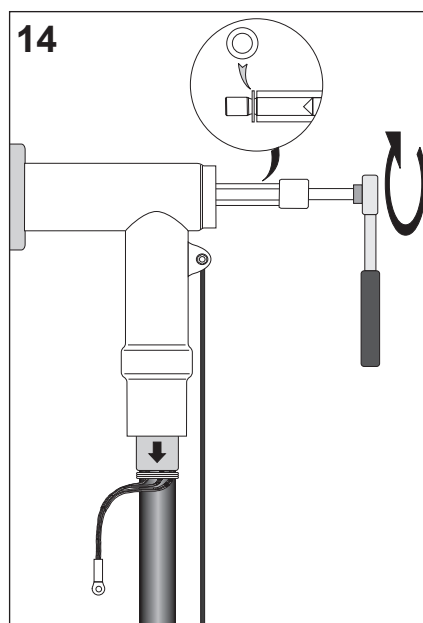
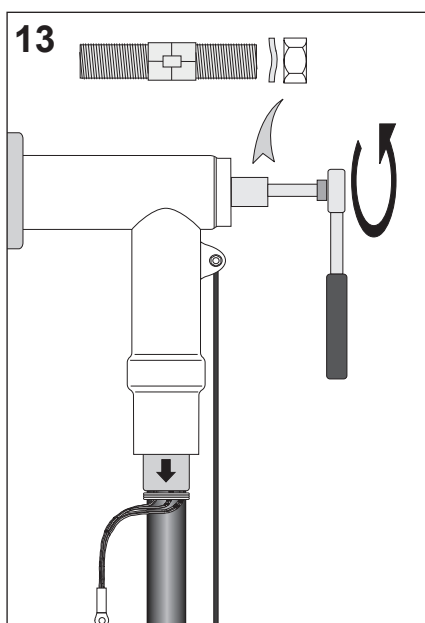

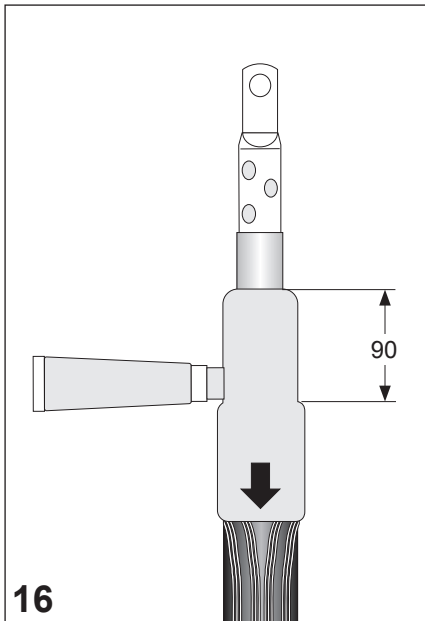

16
Clean the outer surface of stress cone and apply a thin layer of lubricant onto the outer surface of the stress cone over a length of 90 mm with the sponge top as shown in the drawing.

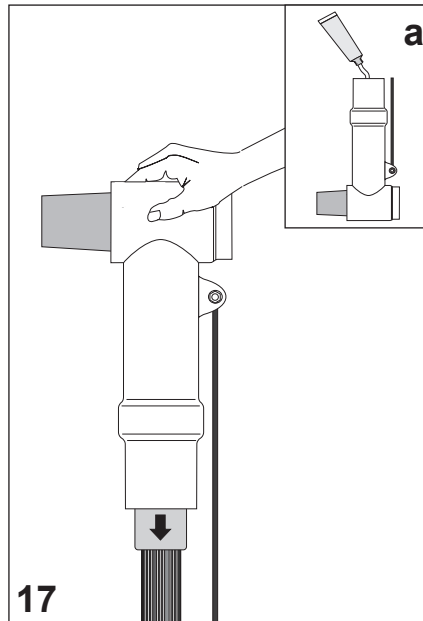

17
Clean the coupling connector body at the bottom end and apply a thin layer of lubricant onto the inner surface without the sponge top as shown in detail a.

Note: Use one way glove to evenly lubricate the inner surface at a length of approx. 50 mm.

Push the coupling connector body with no interruption onto the stress cone and hold it.

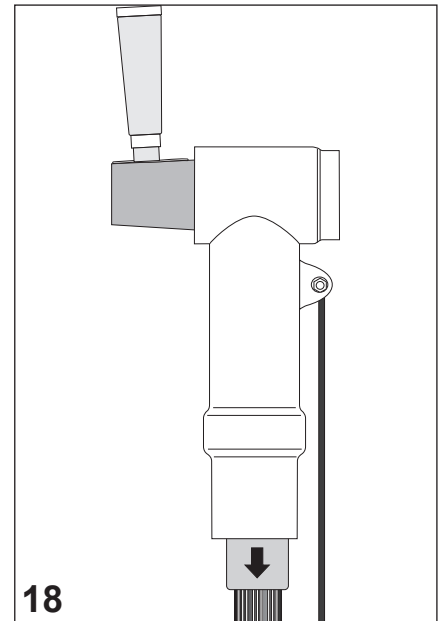

18
Clean the conical front end of the coupling connector and apply a thin layer of lubricant onto the outer surface of the cone with the sponge top. Continue **immediately** with the next step.

Align the conical front end of the coupling connector with the rear end of the already installed connector and push the coupling connector in position.

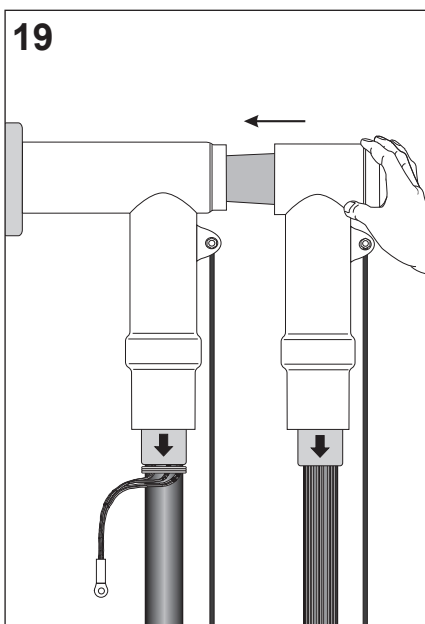

Insert the spring washer and hex nut as removed in step 13. Tighten the hex nut onto the stud with a torque wrench (24 mm) at a torque of 30 Nm.

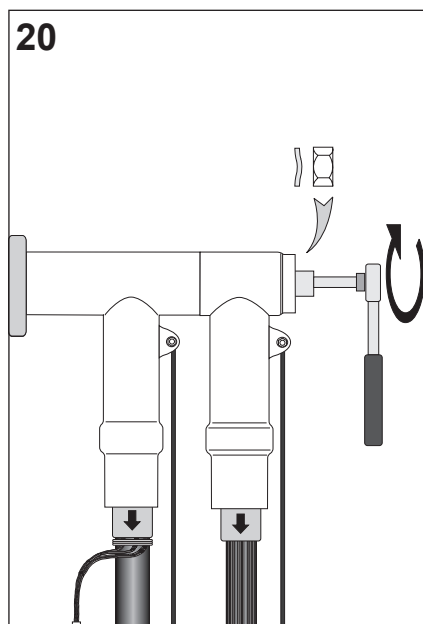

Clean the inner surface of connector back end and apply a thin layer of assembly lubricant. Do the same with the conical interface of the back plug removed in step 12 (see also detail in drawing).

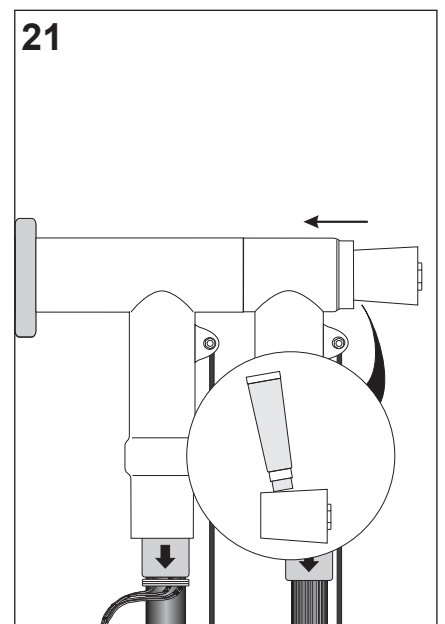

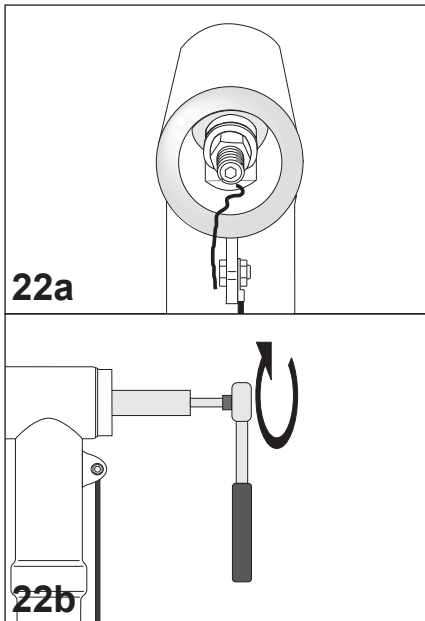

- a. Place a string into the rear entry of the connector as shown.
- b. Insert the back plug and screw it into place using a spanner (19 mm) at a torque of **30 Nm**.

Remove the string prior to the last two turns.

Note: Back plug has to be flush with connector end. In case of protrusion of back plug check steps 13 - 15 for correct installation of components.

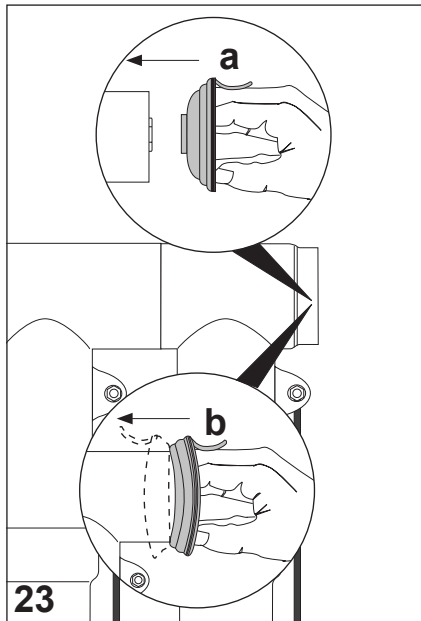

- a. Flip-back the endcap as shown in detail **a**. Position the protruding ring onto test point.
- b. Flip the endcap into final position with your finger as shown in detail **b**.

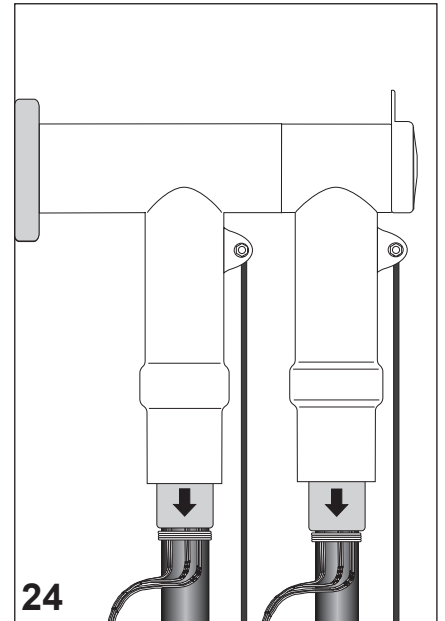

Ensure that the grounding lead is fastened tightly.
Fix the shielding wires with a wire binder (four layers) at the end of the stress cone.
Gather the wires together to form an earth lead. Install at the end of the shielding wires the connection lugs supplied in the kit.

Perform connection to ground.

Note: Ensure that each cable is fixed with suitable cable cleats onto cable rack at a distance of 400 mm from the center of the bushing.

Screened separable coupling connector completed.

Please dispose of all waste according to environmental regulations.

