



MÉDIA TENSÃO

Disjuntor Externo SIEMENS

tensão corrente Icc - kA uso garantia embalagem

72,5 kV 2500A 31,5kA

EXTERNO

12
MESES

engradado
de
madeira

145 kV 3150A 40 kA

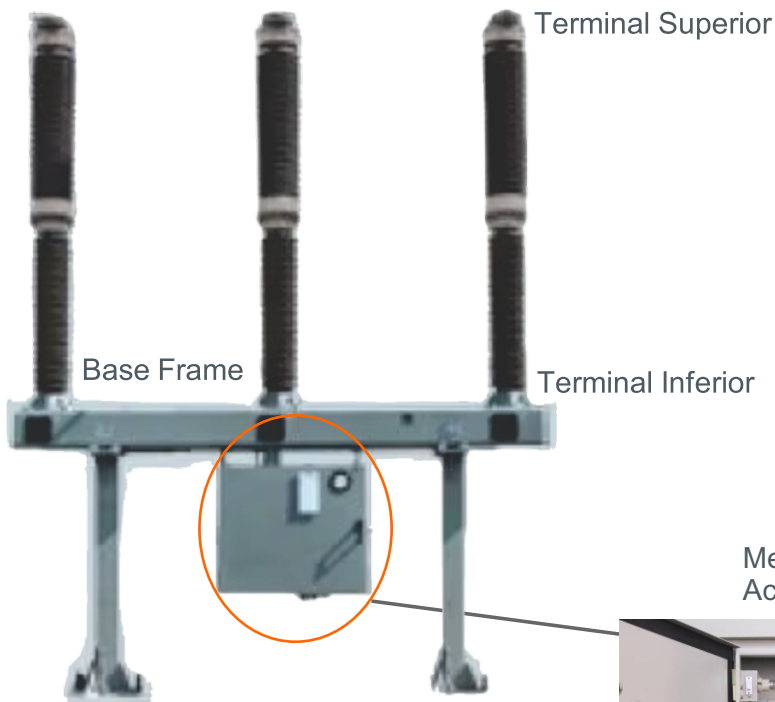

Estrutura de Metal



Soluções Elétricas de 15 a 36kV

Conheça nossos itens para Subestações em Alta Tensão



Soluções a partir de 69kV

Consulte nossas versões para Cabines Primárias e Subestações de Entrada



Fone 11 2384-0155

Guarulhos - SP

www.mediatensao.com.br

Restrito

VISTA FRONTAL

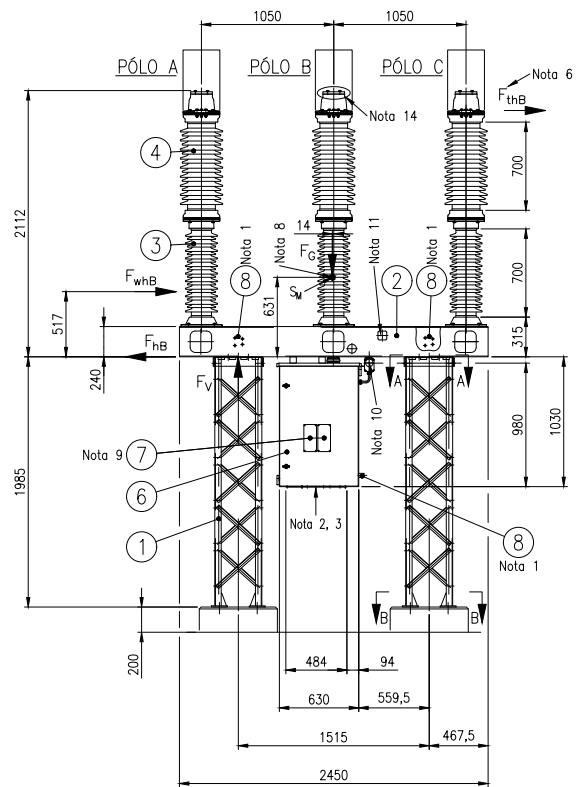

VISTA LATERAL

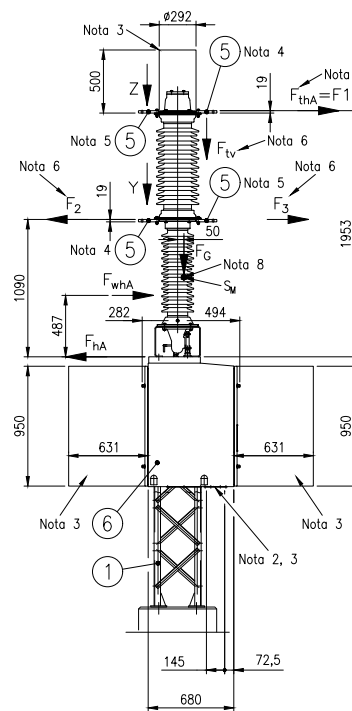

VISTA Z

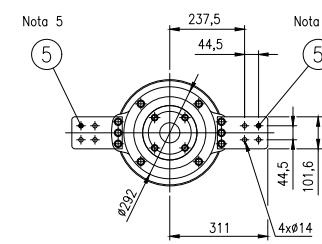

VISTA Y

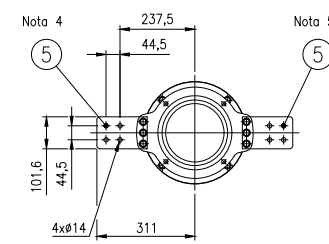

CORTE A-A

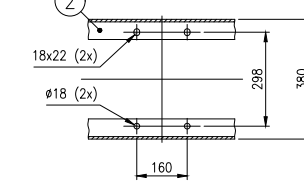

FURAÇÃO P/ ATERRAMENTO

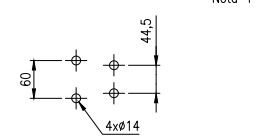

OBs:

- MECANISMO DE ACIONAMENTO A MOLA.
- DIMENSÕES EM MILÍMETROS, EXCETO INDICAÇÃO CONTRÁRIA.
- SÃO POSSÍVEIS PEQUENAS DIVERGÊNCIAS DAS MEDIDAS E DADOS INDICADOS.

NOTAS:

- PONTOS DE ATERRAMENTO PARA TERMINAIS M12, VER TABELA 2.
- ABERTURA PARA SAÍDA DE CABOS.
- ESTE ESPAÇO DEVERÁ FICAR LIVRE PARA CONTROLES E DESMONTAGENS.
- TERMINAL DE AT, C/FUROS SEGUNDO NEMA, MONT. PADRÃO C/TERMINAIS OPOSTOS.
- OPCIONALMENTE, NA OBRA, OS TERMINAIS PODERÃO SER MONTADOS EM OUTRA CONFIGURAÇÃO.
- TRAÇÃO ADMISSÍVEL DO CABO AÉREO:
 - APLICANDO-SE AS FÓRMULAS SEGUINTEs, CONSIDERAR VALORES DA TABELA: $F1 \leq F$; $F2 \leq F1 \cdot 1,94$; $F1 + F3 \cdot 0,51 \leq F$
- DIMENSÕES DE FIXAÇÃO PARA MONTAGEM SOBRE A ESTRUTURA SUPORTE.
- CENTRO DE GRAVIDADE.
- PLACAS DE CARACTERÍSTICAS DO DISJUNTOR (DADOS ELÉTRICOS E MECÂNICOS).
- VISOR DO MANÔMETRO DE SF6.
- INDICADOR MECÂNICO DE POSIÇÃO (1 - FECHADO / 0 - ABERTO).
- DIMENSÕES DE FIXAÇÃO DA ESTRUTURA SUPORTE SOBRE A BASE DE CONCRETO.
- ESFORÇOS NOS TERMINAIS CONFORME IEC 62271-100, PONTO 6.101.6.2 SEÇÃO B.
- DISPOSITIVO DE ALÍVIO DE PRESSÃO INTERNA.

VISTA DE TOPO

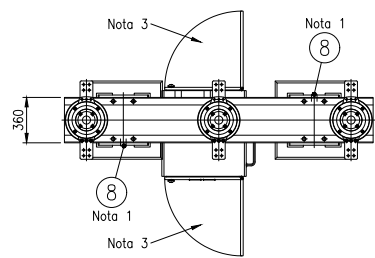

CORTE B-B

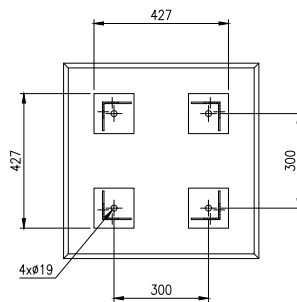

CONECTOR DE ATERRAMENTO

CABO DE COBRE
BITOLA: 35mm² a 185mm².



TABELA 2

POS.	REF. DELTA STAR	ROSCA	QT.	APLICAÇÃO
2				VIGA BASE
2				ESTR. SUPORTE
1				ARM. ACIONAM.

NOTA 13

Stat.	CARGAS NOS TERMINAIS		
	F_{thA}	F_{thB}	F_{tv}
	750 N	500 N	750 N
Stat. + Din.	1500 N	1000 N	1500 N

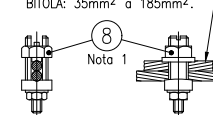
FORÇA DE MANOBRÁ POR ESTRUTURA

FG	F_{whA}	F_{whB}	F_{hA}	F_{hB}	F_v
Velocidade de vento	Carga operacional horizontal				
33 m/s	Carga operacional vertical				
7,8 kN	1,5 kN	1,35 kN	0 kN	±6,6 kN	+14,7 kN (tração) -23,4 kN (compres.)

Nº	Discriminação das revisões	Data	Nome	Data	Visto
0	Emissão inicial.	11/11/24	H. Lisboa	25/10/2024	
			Desenhado	H. Lisboa	
			Verificado	R.Duran	
			Aprovado	R.Duran	
			Nº cliente.		

POS.	DESCRIÇÃO	QT.	REFERÊNCIA	OBs.
10				
9				
8	CONECTOR DE ATERRAMENTO M12	5	K2F-111-P-AE	DELTA STAR (VER TAB. 2)
7	PLACA DE CARACTERÍSTICAS	1		SIEMENS (AÇO INOX)
6	ARMÁRIO DE ACIONAMENTO E COMANDO	1		SIEMENS
5	TERMINAL DE ALTA TENSÃO (ALUMÍNIO)	6		SIEMENS (NOTAS 4,5)
4	UNIDADE INTERRUPTORA	3		SIEMENS
3	ISOLADOR SUPORTE	3		SIEMENS
2	BASE DO DISJUNTOR	1		SIEMENS (ZnFg)
1	ESTRUTURA SUPORTE	2		SIEMENS (ZnFg)



Nº des: 2HM B2572.0007/25
Esc: 1:30 Localiz: Fáb: 1/1

Cliente: MT COMERCIAL ELETRICA LTDA
Identif.:
Título: DISJUNTOR A SF6
TIPO 3AP1 FG3 72,5 kV - 2500 A - 31,5 kA
DIMENSIONAL - DISJUNTOR

Rev: 0

SIEMENS
energy

High-Voltage Circuit Breakers

From 72.5 kV up to 1100 kV



Siemens Energy is a trademark licensed by Siemens AG.



Customized products with the shortest delivery times from our global production network

03	Foreword				
04	Modular design				
05	Control				
06	Monitoring				
07	Interruption principles				
08	Drive system				
09	Development and routine testing	11	Live tank circuit breakers	15	Dead Tank Compact
10	Installation and commissioning	13	Dead tank circuit breakers	16	Disconnecting Circuit Breaker

[Live tank circuit breakers](#)[Dead tank circuit breakers](#)[Compact switchgear](#)[Disconnecting Circuit Breaker](#)

3AV1 FG Blue 145 kV



3AP4 FI 800 kV pole

Circuit breakers from Siemens Energy

The availability of electric energy is vital for economic development and for quality of life and the demand is constantly increasing. One of the necessary conditions for a reliable electric power supply is a well-functioning transmission system.

Siemens Energy worldwide supports customers along the entire chain of energy conversion, with an efficient range of products, solutions and know-how for the transmission of electrical energy from one source.

Circuit breakers are the central part of air-insulated (AIS) and gas-insulated (GIS) switchgear. High-voltage circuit breakers are mechanical switching devices which connect and break current circuits (operating currents and fault currents) and carry the nominal current in closed position.

As a world market leader, Siemens Energy takes the responsibility to provide circuit breakers which meet highest environmental, technological and economic conditions in the various countries worldwide.

For more than 150 years we have been shaping and improving the energy world. More than 220,000 circuit breakers delivered to 150 countries prove this.

Sustainability is the core of our actions

Siemens Energy is fully committed to supporting worldwide agreements and sustainable development goals of nations and our customers. Our ambition is to achieve climate-neutrality in our own operations by 2030 and to cover 100% of our own electricity consumption from renewable sources by 2023. Furthermore, we want to make power grids completely free of greenhouse gas emissions with highest performance and health and safety standards. Sustainable means for us: Zero SF₆ gas, Zero F-mix-gases and Zero greenhouse gases. Our Blue products with vacuum interruption and clean air insulation combine the game changing technology paving the way for climate neutral high-voltage switchgear.

[read more ... >](#)

Modular design

Few basic components leading to a high diversity of types

High-voltage circuit breakers from Siemens Energy, regardless of type or voltage range, are designed in a well proven modular platform concept. This leads to a high diversity of circuit breaker types and to high flexibility with regard to various applications according to our customers' requirements.

The main components, such as

- operating mechanism,
- control system,
- base frame,
- kinematic chain and
- insulator designs (DT / DTC)
- current transformers (DT / DTC)
- pre-insertion resistors (PIR)

are identical and based on decades of manufacturing and operating experience. Our GIS switchgear range also includes the same interrupter units, operating mechanisms and control elements. By applying this proven modular design not only at our lead factory in Germany, but also within our global manufacturing network, we are able to fulfill the highest expectations regarding availability and reliability at eminently competitive prices.

This modular principle can also be found in the type definition of our high-voltage circuit breakers.

Basic components

Type designation

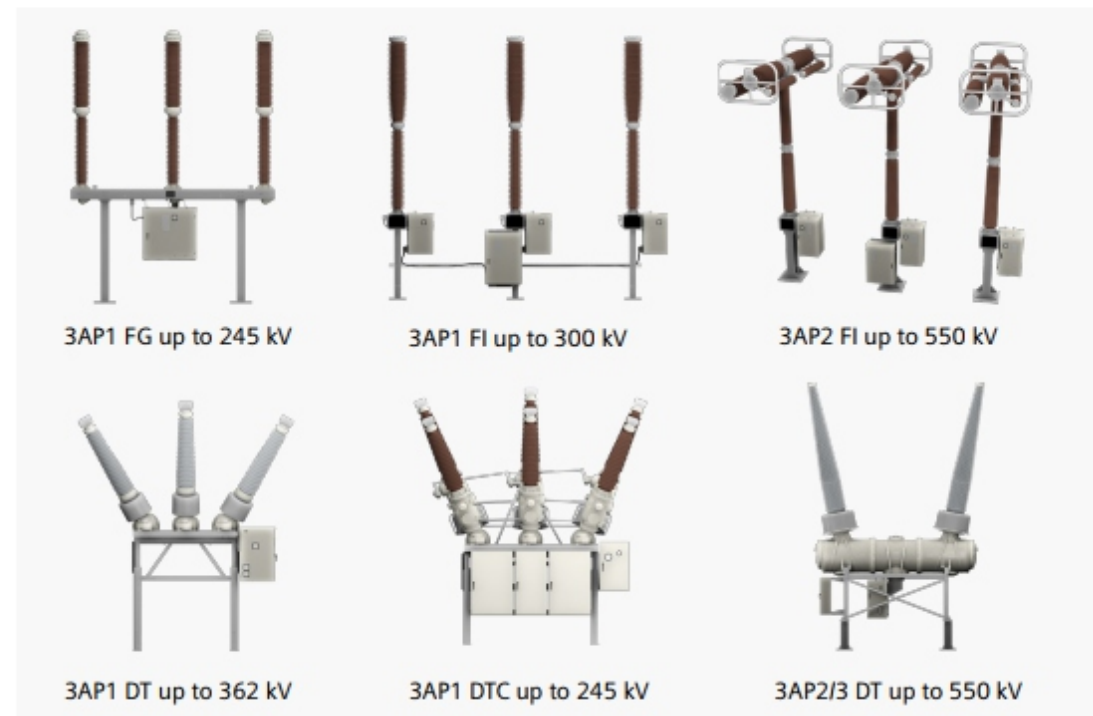

All construction types consist of the same basic components:

- | | | |
|---------------------|--------------------|--------------------------------|
| 1. Interrupter unit | 3. Pillar | 5. Operating mechanism cubicle |
| 2. Post insulator | 4. Control cabinet | 6. Closing resistor |

Control

The control system includes the secondary technical components required for operating the circuit breaker, which are mainly arranged in the control cabinet. The control, tripping, motor and heating power supplies can be selected by the customer. Two standard control variants are available depending on your requirements.

Basic variant

The basic variant includes all control and monitoring elements that are needed for operation of the circuit breaker, including the following:

- Switching operation counter
- 19 auxiliary switch contacts (9 normally open, 9 normally closed, 1 wiper contact)
- Local actuator

Compact variant

In addition to the basic variant, this compact variant includes:

- Spring monitoring by motor run time monitoring
- Heating monitoring (current measuring relay)
- Light and socket attachment with a common circuit breaker to facilitate servicing and maintenance work
- Overvoltage attenuation
- Motor circuit breaker
- Heating circuit breaker

Special customer adapted solutions can be offered on request.



Cabinet with control and stored-energy spring drive mechanism

Circuit breaker monitoring

Sensgear™ – Born connected

While monitoring equipment can already provide a lot of information, the focus of Sensgear™ is goes beyond common asset management, it supports active management of the grid. With Sensgear™ the gas-insulated switchgear or circuit breakers transmit their current status in near-real time via an online application. This facilitates qualified decision-making and optimized grid management, which results in more flexibility and more economic operation and a reduction of unplanned downtime.

Please contact your local sales or visit our [website](#) for most recent information.

Beneficial applications

- Preventive detection of suspicious & critical assets thereby reducing the risk of unplanned outages
- Early warning and push notification on mobile devices before it gets critical
- Reduced manhours on equipment with less costs & time for travel and SF₆ controlling at site
- Cost savings for unplanned SF₆ leakage repairs
- Less risk contingencies and penalties for SF₆ emissions
- Mechanical lifetime trending and projection
- Fleet coverage in a unified manner
- Artificial intelligence powered analysis
- Comprehensive visualization tools to support further decision making

Sensgear™

Edgegear™

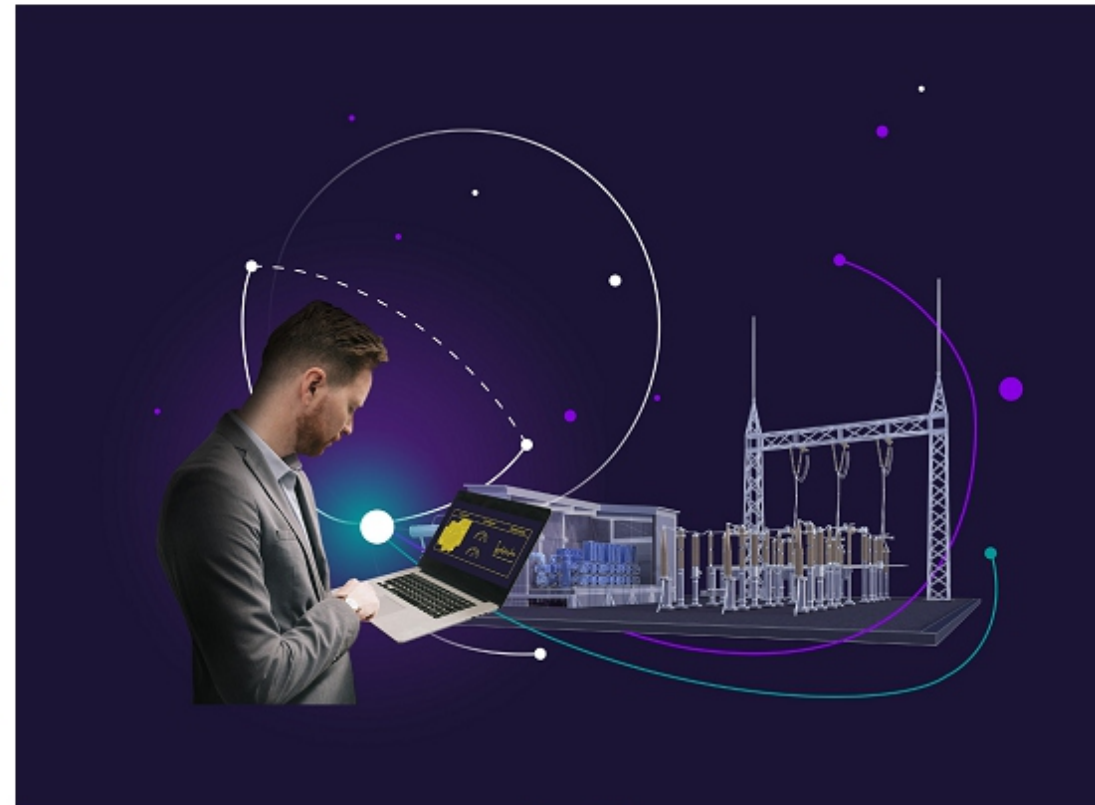
Controlled switching
with PSDControlled contacts
with SICEA01

1 2

Interruption principles

Vacuum interruption principle

Vacuum interrupters form the backbone of our 3AV1 blue portfolio. Based on more than 40 years of experience in medium-voltage range and more than 6 million delivered vacuum interrupters, Siemens Energy has introduced this proven technology to high-voltage power networks in 2010. The technology is characterized by a number of distinctive features, such as

- High reliability due to the hermetically tight vacuum interrupter
- No toxic materials or decomposition products
- Perfect for low temperatures, no liquefaction of switching medium

- High performance, low arc energy, and very low erosion during switching operations, resulting in excellent interruption performance, e.g. in terms of high numbers of current interruptions for rated and short-circuit currents
- No maintenance due to sealed for life technology
- No greenhouse gas usage or emissions

[read more ... >](#)

Vacuum interruption principle

Clean air insulation

Self-compression principle

Dynamic self-compression principle

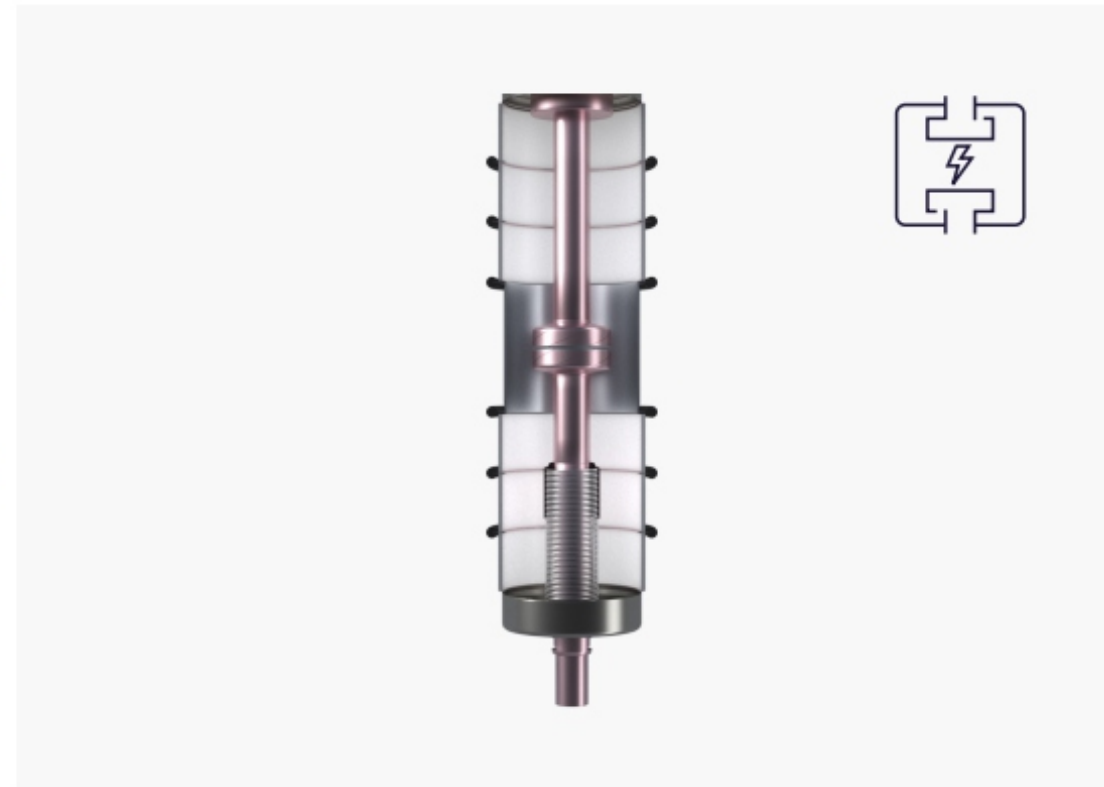

1. Insulating envelope
2. Fixed contact

3. Movable contact
4. Bellow

Drive system

Stored-energy spring mechanism

The operating mechanism is a central part of high-voltage circuit breakers. The drive concept of the 3AP circuit breaker family is based on the patented stored-energy spring principle and is identical on all types. The use of such an operating mechanism for voltage ranges of up to 1100 kV became appropriate as a result of the development of a self-compression interrupter unit that requires minimal actuating energy. The compact design of this operating mechanism makes it possible to place the stored-energy spring mechanism within the control cubicle in a compact housing.

The mechanism types differ in terms of the number, size and arrangement of the opening and closing springs. Both the closing and opening springs are located inside the operating mechanism, thereby achieving a simple and sturdy device. This design minimizes the number of required moving parts. The use of roller bearings and of the maintenance-free charging mechanism is a prerequisite for reliable operation over decades. Proven design principles such as vibration-isolated latches and load-free isolation of the charging mechanism were retained.

[read more ... >](#)



1. Switching rod
2. Trip coil CLOSE
3. Charging gear
4. Opening latch
5. Connecting rod for opening spring
6. Connecting rod for closing spring
7. Trip coil OPEN
8. Opening spring
9. Closing spring

Quality right from the start

Development and type testing

The foundation of quality for Siemens Energy circuit breakers begins right in the development of a new product. Switching performance, high voltage stability and performance under normal mechanical loads (wind and short circuits) as well as seismic conditions are simulated and optimized in the outline design phase using digital twins. The use of parts and assembly units in a large number of breaker types such as live tank, dead tank, as well as GIS leads to a high volume standardization of the main components. Steady and regular amounts of produced units form a continuous production process and ensure the highest standards. Statistical quality control is based on large numbers produced, and hence, a higher validity is achieved.

All our circuit breakers are completely type-tested in accordance with latest IEC, ANSI and other standards before their market launch. In our lead factory in Berlin, we have one of the most modern testing laboratories available which are accredited according to IEC 17025, part of the European network of the independent testing organization, PEHLA as well as member lab of the Short-Circuit Testing Liaison (STL).

All required facilities are available:

- Basic research and vacuum switching laboratory
- High-voltage testing laboratory
- High-power testing laboratory
- Mechanical testing laboratory
- Temperature rise testing laboratory

[read more ... >](#)

Development and type testing

Routine testing

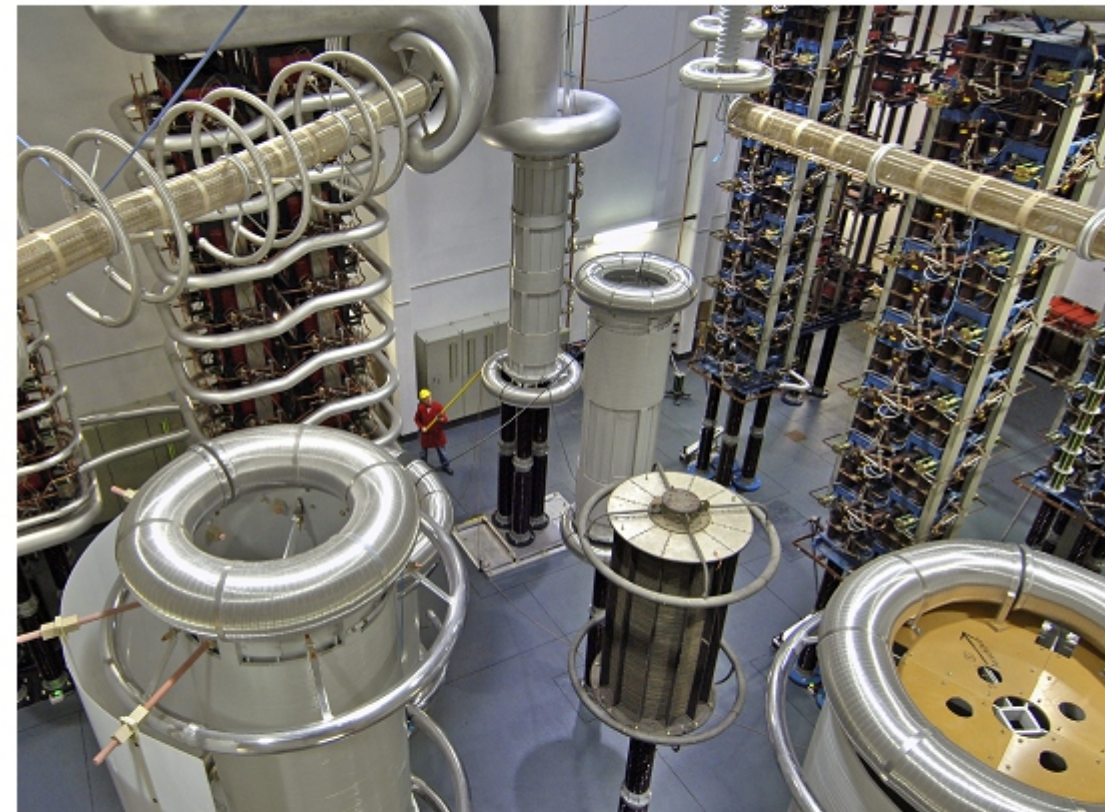

Easy installation and commissioning

Our circuit breakers for voltage ratings from 72.5 kV to 300 kV can be transported fully pre-assembled and routine-tested. All higher ratings are dismantled into compact, clear and space saving subassemblies for transportation purposes. Transportation costs are minimized by packing several circuit breakers together in one shipment. The subassemblies can quickly be installed into a complete circuit breaker at the substation. A single supervisor can install one circuit breaker within one and a half days. Due to the fact that the circuit breaker is already routine-tested in the factory, commissioning can be reduced to a minimum and there is no need for special tools or equipment.

Lifelong service for the circuit breaker

We provide installation, commissioning and maintenance on request. And once installed, Siemens Energy circuit breakers will operate safely and reliably for years. But in the unlikely event of a fault, you can rely on our worldwide customer support.

We offer service attendance throughout the entire operating life of the circuit breaker. Inspection, maintenance, repair and a round-the-clock fault service give you the necessary backup.

[read more ... >](#)



1 2

3AV1FG Blue live tank circuit breaker

Vacuum technology is the game changer for F-gas-free high-voltage power grids

The outstanding technical performance and low lifecycle costs of vacuum circuit breakers make this solution the preferred technology and led to a phase out of SF₆ in power networks up to 52 kV. The same proven technology paved the way for climate-neutral high-voltage applications of Siemens Energy since 2010.

The member of our Blue product family is designed according to our well proven modular platform concept and meets the same high quality standards as our SF₆ portfolio. Moreover, it has a number of features superior to SF₆ circuit breakers. These include 30 full short-circuit current

interruptions, 10,000 rated current interruptions, optional 2-cycle current interruption, full performance down to -60°C ambient temperature, and maintenance-free interrupter unit during its lifetime.

Zero greenhouse gases:

- Greenhouse- and F-gas free insulation
- No CO₂ emissions

[read more ... >](#)

Gallery

Portfolio

Technical data



World's first substation with SF₆-free switchgear technology from Siemens Energy in a 110 kV high-voltage grid (Noerdlingen, Germany 2018)

1 2

3AP live tank circuit breaker

For applications from 72.5 kV up to 1100 kV

In contrast to dead tank circuit breakers, the interrupter unit in live tank breakers is not grounded during operation; it is exposed to high-voltage potential and therefore these circuit breakers are called live tanks.

The 3AP circuit breaker family is available for rated voltages from 72.5 kV up to 1100 kV. 3AP1 circuit breakers up to 300 kV are equipped with one interrupter unit per pole and 3AP2 circuit breakers up to 550 kV include two interrupter units. For applications from 362 kV to 550 kV, the circuit breakers can be equipped with optional closing resistors (3AP3). For higher voltage levels, the 3AP4 includes 4 interrupter units

per pole and can also be delivered with closing resistors on request (3AP5).

Moreover, our high-voltage live tank circuit breakers are available for three-pole operation with a common base (FG), for single pole operation also with a common base (FE) or for one pole operation with separate bases (FI). In accordance with our modular design, all 3AP live tank breakers are equipped with our stored-energy spring drive mechanism and our self-compression interrupter units.

[read more ... >](#)

Gallery

Portfolio

Technical data



3AP1 FG 245 kV



3AV1DT Blue dead tank circuit breaker

Vacuum technology is the game changer for F-gas-free high-voltage power grids

The outstanding technical performance and low lifecycle costs of vacuum circuit breakers make this solution the preferred technology and led to a phase out of SF₆ in power networks up to 52 kV. The same proven technology paved the way for climate-neutral high-voltage applications of Siemens Energy since 2010.

The brandnew member of our Blue portfolio is the world's first climate-neutral 123 kV dead tank breaker, fully type tested according to IEEE and ANSI standards and will be installed at a pilot customer in California. We are proud to be joining our customers in taking the next steps toward sustainable power transmission with no greenhouse

gas or any other F-gas emissions and to achieve their goals on climate protection. The Blue dead tank breakers offer rated voltages up to 145 kV, a rated short-circuit breaking current of up to 63 kA and a rated current of up to 3,150 A, whilst providing easiest possible operating and recycling processes.

[read more ... >](#)

Gallery

Portfolio

Technical data

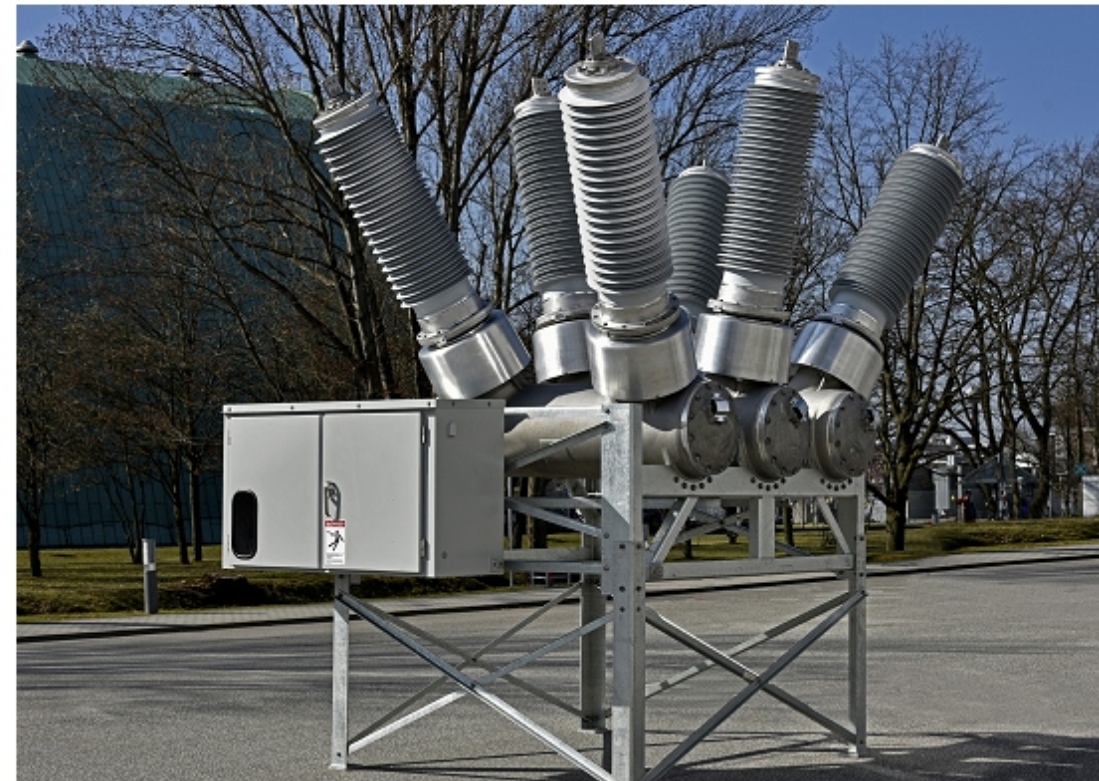

3AV1DT 145 kV

3AP dead tank circuit breaker

For applications from 72.5 kV up to 550 kV

In contrast to live tank circuit breakers, dead tanks have a metal-enclosed interrupter unit, and the housing is always grounded. Therefore, they are called dead tank circuit breakers. For certain substation designs, dead tank circuit breakers might be required instead of the standard live tank breakers. The dead tank breaker offers particular advantages if the protection design requires the use of several current transformers per pole assembly.

Most important characteristics of a dead tank breaker:

- Toroidal-core current transformers on bushings (compact construction)

- High short-circuit breaking currents possible (up to 90 kA with one interrupter unit)
- Low center of gravity of the bases (higher seismic withstand capability)
- Gas mixture or heating system for lowest temperature applications
- Gas-insulated components ensure highest availability with minimum maintenance effort
- 362 kV and 550 kV available with pre-insertion resistor (PIR) solution

[read more ... >](#)

Gallery

Portfolio

Technical data



3AP1 DT 145 kV

1 2 3

3AP1 DTC Dead Tank Compact

For 145 kV and 245 kV applications

The hybrid concept on which the 3AP1 Dead Tank Compact (DTC) is based combines SF₆-encapsulated components and air-insulated devices. The application of gas-insulated components increases availability of the switchgear. According to CIGRE analyses, gas-insulated components are four times more reliable than air insulated components. Furthermore, safety can be enhanced by separating gas compartments, e.g. between the circuit breaker and disconnector.

The DTC circuit breaker is a compact arrangement of several functions needed in a substation. The elements of this compact switchgear is a dead tank circuit

breaker, fitted with one or two current transformers, one or more disconnectors, earthing switches and bushings as applicable for connection to the bus bar system.

And of course, based on our modular design, the core components are adopted from our high-voltage circuit breakers, disconnectors and GIS product family. Due to the compact design and the flexible use of predefined modules, different layouts can be realized with a minimum of engineering effort.

[read more ... >](#)

Gallery

Portfolio

Technical data



3AP1DTC 145 kV



3AP DCB Disconnecting Circuit Breaker

For 145 kV and 420 kV applications

In switchgear, isolating distances in air combined with circuit breakers are used to protect the circuit state in the grid.

Siemens Energy has developed a device in which the isolating distance has been integrated in the SF₆ gas compartment in order to reduce external environmental influences. The DCB (Disconnecting Circuit Breaker) is used as a circuit breaker and additionally as a disconnector – two functions combined in one device.

The DCB was developed on the basis of a higher-rated standard 3AP circuit breaker to provide the higher dielectric properties required. Due to the SF₆-insulated disconnector function there is no visible opening distance anymore.

The proper function of the kinematic chain has been most thoroughly verified. The closest attention was paid to developing a mechanical interlock which guarantees that the circuit breaker remains in the open position when used as a disconnector.

When this mechanical interlock is activated, it is impossible to close the breaker. The current status of the DCB can also be monitored electrically and is shown by clearly visible position indicators.

[read more ... >](#)

Gallery

Portfolio

Technical data



3AP1DCB 145 kV



Published by

Siemens Energy Global GmbH & Co. KG
Transmission
Freyeslebenstraße 1
91058 Erlangen
Germany

For the U.S. published by
Siemens Energy, Inc
Transmission
4601 Six Forks Road
Raleigh, NC 27609
USA

For more information, please visit our website:

or contact us: circuit-breaker@siemens-energy.com

© Siemens Energy, 2022

Siemens Energy is a trademark licensed by Siemens AG.

Subject to changes and errors. The information given in this document only contains general descriptions and/or performance features which may not always specifically reflect those described, or which may undergo modification in the course of further development of the products. The requested performance features are binding only when they are expressly agreed upon in the concluded contract. All product designations may be trademarks or product names of Siemens Energy Global GmbH & Co. KG or other companies whose use by third parties for their own purposes could violate the rights of the owners.